



GENUINE PARTS

INSTALLATION INSTRUCTIONS

- DESCRIPTION:** Bed Extender
- APPLICATION:** 2005 Frontier Crew and King Cab
- PART NUMBER:** 999T7 BX290 and 999T7 BX190
- KIT CONTENTS:**

Item	Qty	Description
A	1	Right Bent Tube Assembly
B	1	Left Bent Tube Assembly
C	3	Extension Tube
D	1	Sliding Bracket Assembly Set (Available only in Bed Extender kit for Utili-Track)
E	1	Bolt-On Bracket Assembly Set (Available only in Bed Extender kit for non-Utili-Track)
F	6	PT Screws
G	6	Double Wedge Threaded
H	6	Double Wedge Thru-Hole

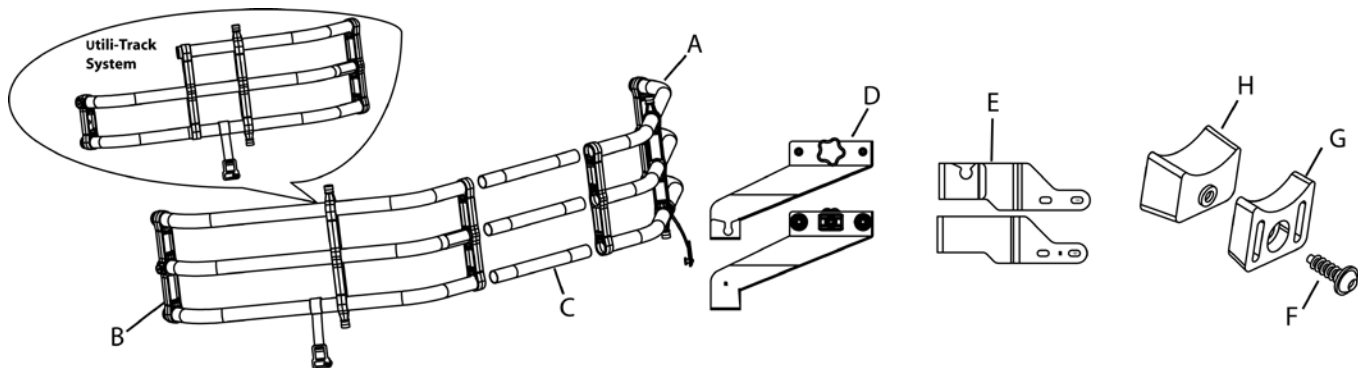

- TOOLS REQUIRED:** T-20 Torx Wrench, Torque Wrench, Tape Measure, 12mm Wrench (bolt-on bracket only).

6. INSTALLATION PRECAUTIONS / NOTES:

CAUTION

- During the assembly and installation process, be careful not to scratch the surface.
- Study illustrations and read the instructions carefully before attempting assembly.
- Maximum load on open tailgate is 91Kg (200 lbs.).
- Keep installation instructions in glove compartment for future reference.
- Do not use bed extender or tailgate to secure cargo.
- Bolt-On Bracket and Sliding Bracket Assembly set does not work simultaneously.

INSTALLATION INSTRUCTIONS

7. INSTALLATION PROCEDURE FOR STANDARD BOLT-ON BRACKETS.

(Skip this section for Bed Extender with Sliding Bracket Assembly set)

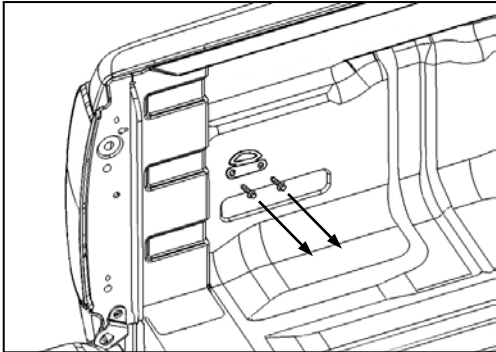

- 1) Remove the bolts that secure the tiedown hooks with a 12 mm wrench. **Do not** discard bolt and tiedown hooks.

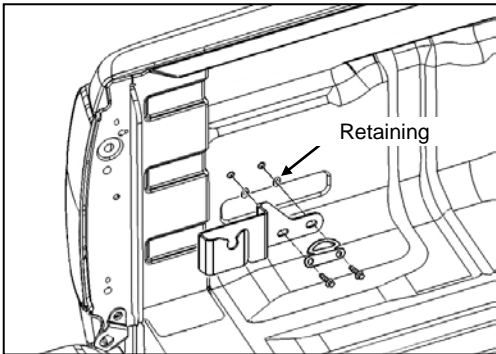

- 2) (Truck with drop-in bedliner, skip to step 3). Re-install the Tie Down Hooks with the Bolt-On Brackets as shown in figure. Tighten the bolts that were removed in previous step to 11-16 N-m (97-142 in-lbf.).

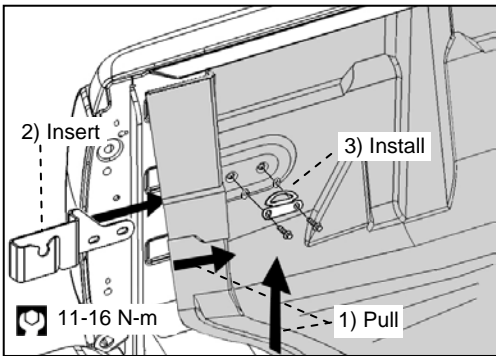

- 3) (Truck without drop-in bedliner, skip this step). Pull the bedliner away from the truck bed sheet metal to insert the Bolt-On Brackets. Re-install the Tie Down Hooks as shown in figure. Tighten the bolts that were removed in previous step to 11-16 N-m (97-142 in-lbf.).

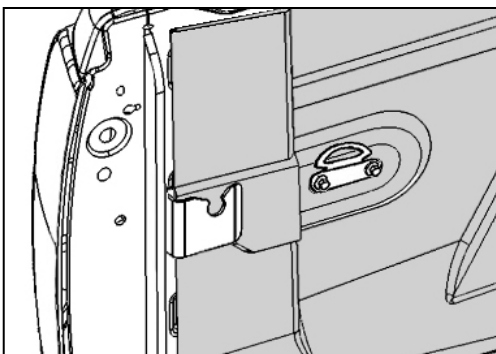

NOTE: The Bolt-On Brackets go between the truck bed sheet metal and the bedliner

INSTALLATION INSTRUCTIONS

8. INSTALLATION PROCEDURE FOR SLIDING BRACKET ASSEMBLY.

(Skip this section for Bed Extender with standard Bolt-On Bracket Assembly set)

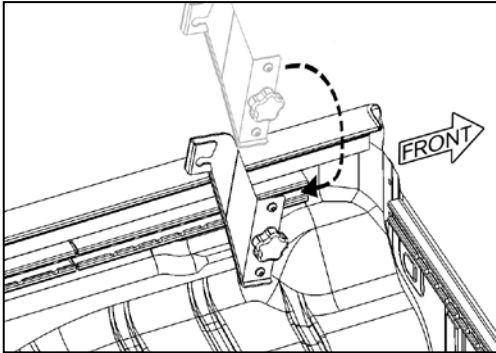

- 1) Wipe away any dirt or debris from the inside surfaces of the Utili-Track C-channels.
- 2) Slide in the Sliding Bracket Assembly into the C-channels.
 - a) Loosen the rubber-coated knob (if not already loosened).
 - b) From the front end of the C-channel, insert the bracket rear roller first by tilting the bracket as shown in the figure.
 - c) As soon as the rear roller slides into the C-channel rail, tilt the bracket back up to insert the plastic clamp and the front roller as shown in the figures.

NOTE: To insert plastic clamp, align the long edge of the plastic clamp to the C-channel.

- d) Repeat step 5a to 5c for the other side.

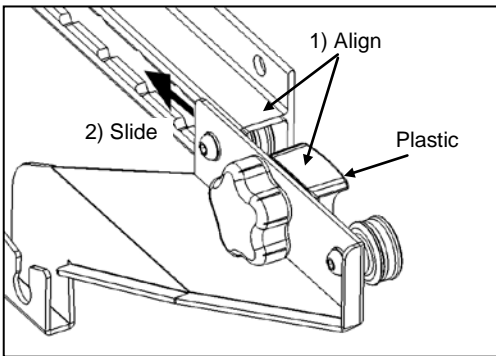
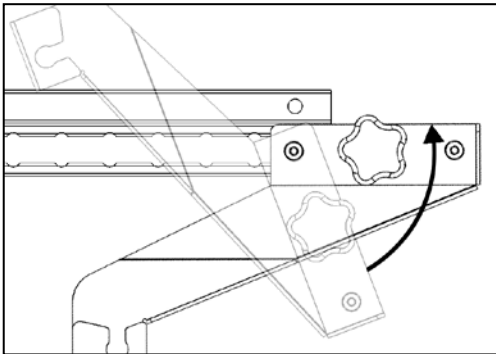

- 3) To secure the Sliding Bracket Assembly position.
 - a) Turn the knob clock-wise until bracket bottoms against the C-channel, then turn about an additional 1/10 to 1/4 turn to tighten (which is about 3.4 N-m to 5.6 N-m or 30 in-lbs to 50 in-lbs).
 - b) Align the other bracket and repeat step 6a.

NOTE: Make sure the left and the right Sliding Bracket Assemblies are aligned with each other.

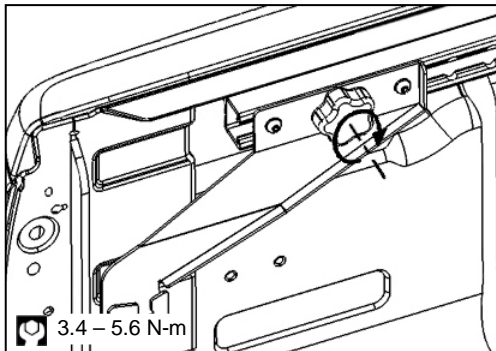

INSTALLATION INSTRUCTIONS

9. INSTALLATION PROCEDURE FOR BED EXTENDER.

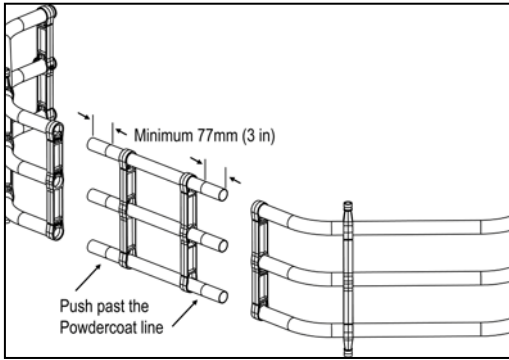

- 1) Slide the Extension Tubes evenly into the Left and Right Bent Tube Assembly.

NOTE: Make sure to slide the extension tubes into the bent tubes at minimum of 77mm (3in). Make sure no bare aluminum surfaces are exposed.

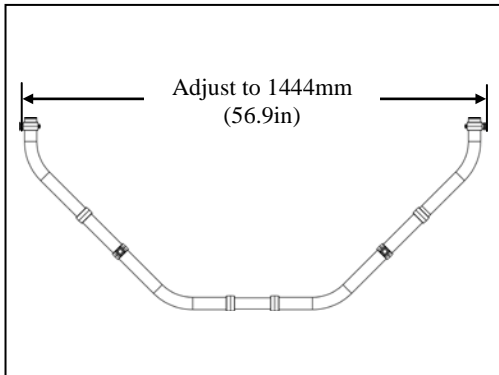

- 2) Adjust the Bed Extender width to about 1444mm (56.9in).

NOTE: Make sure no bare aluminum surfaces are exposed.



- 3) Assembling the double wedges.
 - a) Make sure all bent tubes are positioned all the way into the center upright tube cavities as shown in figure. If not, tap on the center uprights toward the bent tubes.
 - b) Insert double wedges into the wedge cavities.

NOTE: Double wedge thru-hole goes into the center and double wedge threaded goes into the outer side wedge cavities.

- c) Using a T-20 Torx wrench, screw together the double wedges with the PT Screws as shown in the figure. Tighten to 2.3 N-m (20 in-lbf).

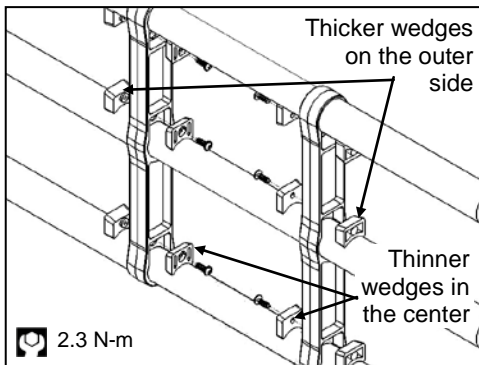

INSTALLATION INSTRUCTIONS

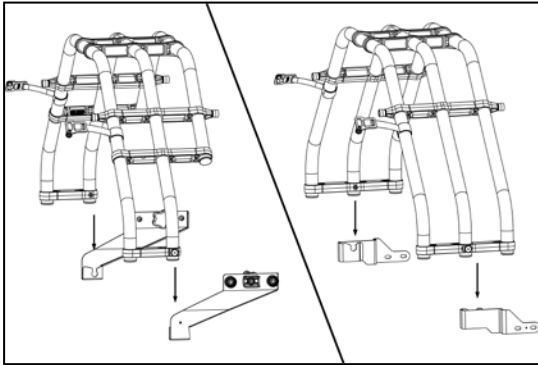

- 4) Assembling Bed Extender into the brackets.
 - a) Hold the Bed Extender at a vertical position.
 - b) Lower the Bed Extender into the brackets and rotate to the desired position (see Bed Extender Usage Position for more detail).

NOTE: 1) If both sides of the extender do not fit into both brackets, it is necessary to engage one side of the extender at a time. Insert one side of the extender into one bracket, and then pull the other side into the bracket so that it is engaged. 2) It is normal for the Extender to have some resistance when it is first rotated in the brackets.

- c) Have the Bed Extender in a vertical position to remove from the brackets.

10. BED EXTENDER USAGE POSITIONS.

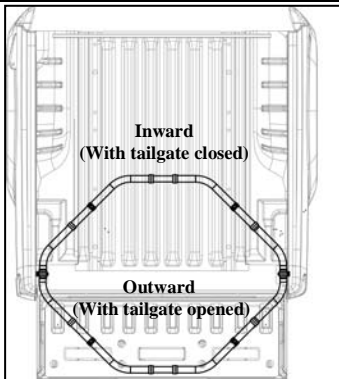

- 1) For the non-sliding bed extender
 - Extender inward and tailgate closed.
 - Extender outward and tailgate closed.

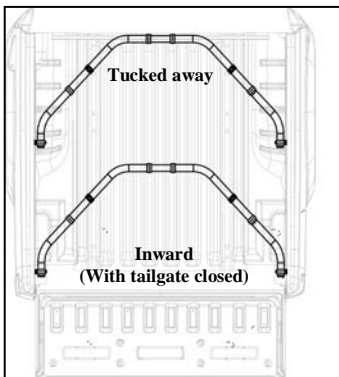

- 2) For the sliding bed extender
 - Extender tucked away.
 - Extender inward and tailgate closed.
 - Extender outward and variable depth.

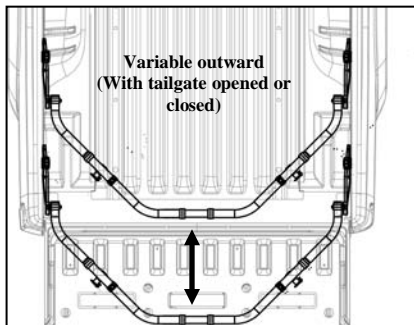

- 3) Re-position the Bed Extender along the C-channel.
 - a) Loosen the rubber knob on the sliding brackets.
 - b) Pick up the Bed Extender and slide to desired position along the C-channel.
 - c) Align the brackets position.
 - d) Tighten the rubber knobs (see step 3 of section 8 for tightening instruction).

INSTALLATION INSTRUCTIONS

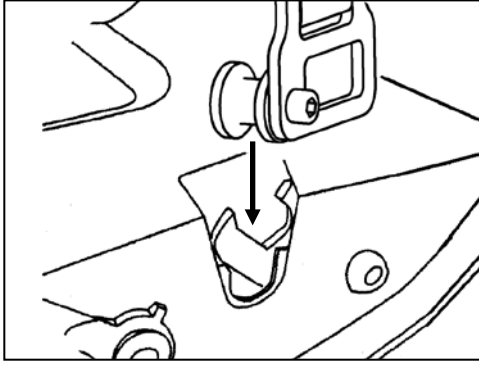

- 4) When the Bed Extender is at the furthest rear position, push down on the buckle to insert into tailgate latch. Tighten straps. To release, pull tailgate handle.

NOTE: Ensure that buckles are properly inserted into latches by pulling on the straps after both buckles have been inserted.